

CATEGORY	DESCRIPTION	P/N #
CONNECTOR	D-SUB 15P 10.5 HIGH, SHORT 9 ASSEMBLY	DB105F-21X1X-XXXX

REV.	ECN NO	DESCRIPTION	REVISED	DATE
A01		New Release	GMC	2010-3-1
A02		新增塑膠无齿规格	JackLiu	2011.01.10

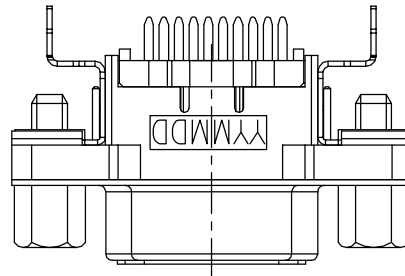

Side view (with Screws)

SPECIFICATIONS

- CONTACT CURRENT RATING:3 Amperes.
- DIELECTRIC WITHSTANDING VOLTAGE:AC 1000/60sec.r.m.s.
- INSULATION RESISTANCE:5000 Medohms MIN.AT DC 500V.
- CONTACT RESISTANCE:25 Milliohms MAX.
- TEMPERATURE:-55°C TO +105°C.
- GROUNDING SCREW TORQUE:3Kg MIN.
- SOLDER HEAT RESISTANCE:WAVE SOLDERING 260° 10sec.
- TO CONFORM TO THE "SONY" DIRECTIVE.
- GREEN PRODUCT IDENTIFICATION LABEL IN PACKING: **G.P. PASS**

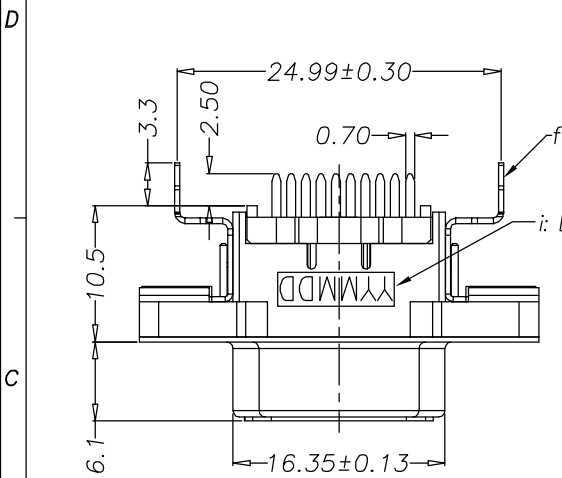

i: DATE CODE:  
YY:YEAR(10~)  
MM:MONTH(01~12)  
DD:DAY(01~31)

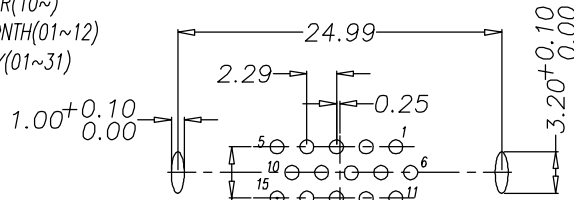

RECOMMEND PCB LAYOUT(TOP VIEW)  
PCB THICKNESS:1.60±0.10mm.  
TOLERANCE:±0.05mm.

PART NO:  
DB105F-21X1X-XXXX

XX	Description
01	w/Sleeve Nut and Jack Screw, pb<=1000ppm, cd<=100ppm
02	w/Sleeve Nut and seperated Hex Jack Screw, With pb<=1000ppm, cd<=100ppm
03	w/Sleeve Nut and fastenedd Hex Jack Screw pb<=1000ppm, cd<=100ppm
04	wo/Sleeve Nut and Jack Screw, pb<=800ppm, cd<=70ppm
05	w/Sleeve Nut and seperated Hex Jack Screw, With pb<=800ppm, cd<=70ppm
06	w/Sleeve Nut and fastenedd Hex Jack Screw pb<=800ppm, cd<=70ppm

COLOR: 00 H:BLACK C:BLACK  
01 H:BLUE C:BLUE  
02 H:BLUE C:BLACK

X	Date Code
0	Without
1	With

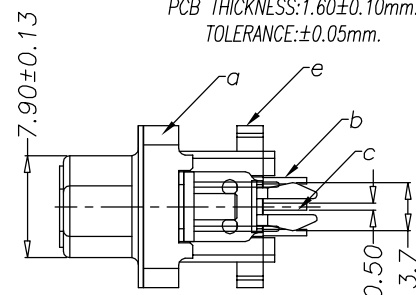
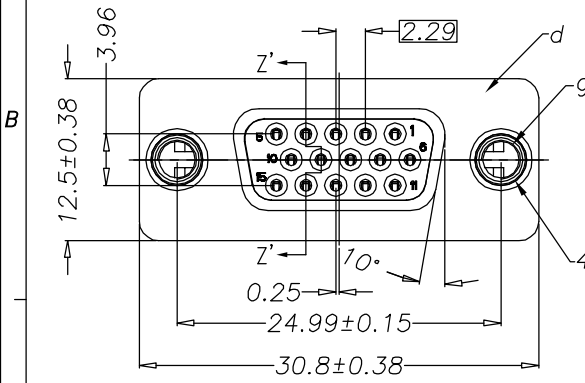
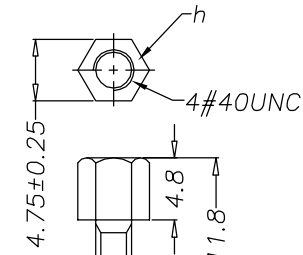
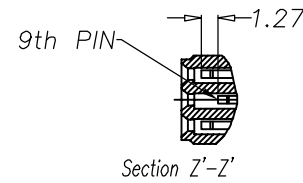

X	CONTACT PLATING
0	Contact area: Gold Flash Plating, Solder area: Bright Tin Plating, PBT 有齿
1	Contact area: Gold Flash Plating, Solder area: Matte Tin Plating, PBT 有齿
2	Contact area: Gold Flash Plating, Solder area: Bright Tin Plating, PBT 无齿
3	Contact area: Gold Flash Plating, Solder area: Matte Tin Plating, PBT 无齿

i	Ink	1	Domino IR-270BK & MC-270BK	Black
h	D-SUB 15P 15 HIGH SCREWS	2	Copper Alloy	Ni Plating
g	D-SUB 15P 15 HIGH RIVET	2	Copper Alloy	Ni Plating
f	D-SUB 15P 10 HIGH LOW COST BOARD LOCK	2	SPCC T=0.40mm	Tin Plating
e	D-SUB 15P 15 HIGH COVER	1	PBT+30%G.F UL94V-0	00:Black;01:Blue 02: 蓝色无齿塑膠 A02
d	D-SUB 15P 15 HIGH SHELL	1	SPCC T=0.40mm	Ni Plating
c	D-SUB 15P 10 HIGH LOW COST SHORT9 CONTACT	5	Phosphor Bronze,T=0.2mm	See Table 1
b	D-SUB 15P 10 HIGH LOW COST CONTACT	10	Phosphor Bronze,T=0.2mm	See Table 1
a	D-SUB 15P 10.5 HIGH HOUSING	1	PBT+30%G.F UL94V-0	00:Black;01:Blue 02: 蓝色无齿塑膠 A02
NO.	DESCRIPTION	Q'TY	MATERIAL	PLATING & COLOR

UNLESS OTHERWISE SPECIFIED TOLERANCES	SCALE:1/1	UNIT: mm	DWG.NO: WI-061-831
	SIZE: A3	PAGE: 10F1	
DECIMALS: X :±0.5 X.X :±0.3 X.XX :±0.2	APPROVED BY XZQ	ANGLES: X :±2° X.X :±1°	CHECKED BY Pengjie
			PREPARED BY GMC
<b>CUSTOMER COPY</b>			